



HYDAC INTERNATIONAL

Process Technology Area / 製成科技領域

Function AutoFilt® ATF TwistFlow Strainer

自動沖洗漩流離心式過濾器

HYDAC Pro-
cess Technol-
ogy



- Qmax** 400 m³/h
- Filtration ratings** Dependent on the particle properties
- Pmax** 16 bar
- Filter elements** Slotted tube
 - Consistent quality of filtrate
 - Continuous filtration
- Advantages**
 - No rotating parts
 - Cleaning by flushing with untreated fluid



Combination of centrifugal separator and inline filter

Consistent quality of filtrate





HYDAC INTERNATIONAL

Process Technology Area / 製成科技領域

Function AutoFilt® ATF TwistFlow Strainer 自動沖洗漩流離心式過濾器

HYDAC Pro-
cess Technol-
ogy



- **1st stage**
- Cyclone-like flow properties tackle high dirt loads and reach filtration performance of a centrifugal separator.
- **2nd stage**
- Conical filter element guarantees the separation efficiency and prevents transfer of dirt to the clean side. Conical filter element guarantees the separation efficiency and prevents transfer of dirt to the clean side.

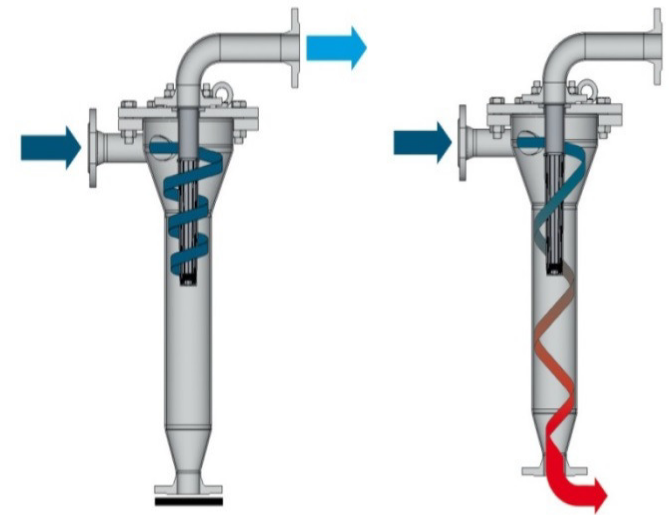

Filtration phase

Cleaning phase

- **Area of application:**
- Preliminary filtration for relieving sand filters
- Pre-filtration of membrane systems
- Filtration of surface water

適合初過濾系統